



ALTUS

Mobile Technology Workstations — Non-Powered



Lightweight
as low as
34 lbs.

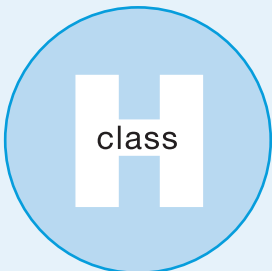

class

Laptop Cart
HLC7P

H Class Laptop Cart HLC7P



Model Number
HLC7P-XX-YYYY
(XX = counterbalance system - refer to pg.13, YYYY = worksurface color, refer to pg.14)

Worksurface Dimensions
20"D x 20"W

Base Dimensions
18"W x 20"D

Weight
42 lbs.



Base

- Reference: **A18P** - Polished
- 18" Height Adjustment (29" - 47")
- 100mm Highly Mobile Rollerblade Casters (2 Locking/2 Non-Locking)
- 18"W x 20"D Footprint
- Height Adjustment Hand Lever

Worksurface

- Reference: **TL2020**
- 1" Dual Surface - 20"W x 20"D
- Integrated Laptop Security System - Keyed
- Adjustable Upper Surface
- 3 Cable Management Grommet Holes
- Integrated Black Vinyl Palm Support

Accessory

- Reference: **SAM-2** (Swing A Mouse)
- 8"W x 9"D

Color

- Standard Color: 0141 (Cloud)



- 1" 3D Laminate with slope edge
- For Additional Color Options See Pg. 14

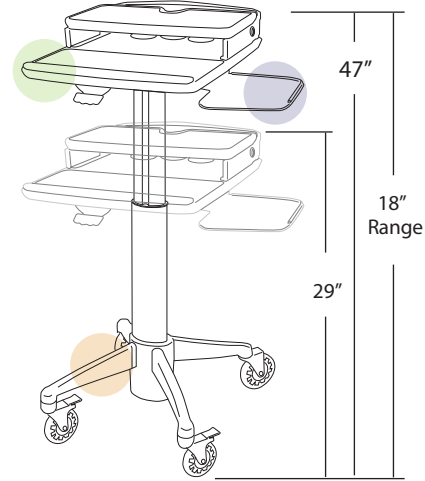

ANSI/BIFMA Compliant

CARB 93120 Compliant

Thermofoil



Alternative Worksurface Colors - Thermofoil with Reversed Teardrop Edge (4 week lead time)

Worksurface spec = 1" 3D Laminate - Rigid Thermofoil Construction.

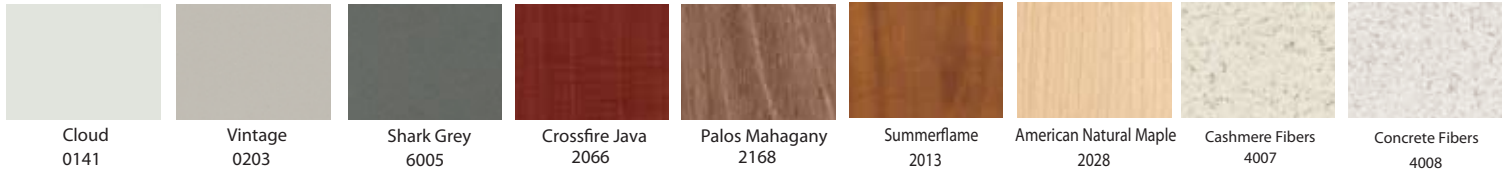

Key Features:



Adjustable Upper Surface Laptop Security Spacing: 2", 2.5", 3" H 20"W x 9"D, No Tools Required



Laptop Lock w/Key for Security & HIPPA



Cable Management Grommet



Back Detail of Laptop Security



Detail of Sloped Edge Worksurface (allows more viewable area of laptop screen)



Swing A Mouse (SAM2) 8"W x 9"D



Height Adjustment Hand Lever



Black Vinyl Palm Support



100mm Highly Mobile Casters 2 Locking/2 Non-Locking



St. Louis, MO
1-888-345-8511

Memphis, TN
1-800-755-0651

Chicago, IL
1-888-345-8511

www.elliottdata.com



AHLC7PSS1007