



Accu-STEAM™ GRIDDLE EG SERIES
Electric/Steam-Heated,
Tabletop Griddle

Project: _____ Location: _____ Item #: _____ Quantity: _____

Short Specification

Griddle shall be an ENERGY STAR compliant electric-heated unit, with a hermetically sealed chamber that produces steam that heats the 7-gauge stainless steel griddle plate. Efficient steam heat transfer provides 200–400°F (93–204°C) operating temperature range and uniform griddle surface temperatures of ±5°F (±3°C). Griddle fabricated from cold-rolled stainless steel with 4" high back splash, sides that taper from 4" to 1 5/16", a 3 7/8" wide by 1/2" deep full front grease trough and 5 - 6 1/2 quart grease drawer. Unit to be UL listed, UL EPH Sanitation Certified (NSF/ANSI 4) and manufactured in the USA.

Construction Features

- Cold-rolled and annealed stainless steel griddle plate with polished stainless steel body
- 7 gauge griddle plate with 4" high rear splash and 4" to 1 5/16" tapered side walls
- 3 7/8" wide by 1/2" deep full front grease trough
- 1 1/2 x 3 1/2" drop chute to 5 [24"], 6 1/2 [36", 48"] quart capacity grease pan
- 4" legs with bullet feet
- Control guard

Performance Features

- Hermetically-sealed steam chamber heats griddle plate
- 9.6-kW [24"] or 14.25-kW [36", 48"] total power, long-life low watt density heating elements mounted inside vacuum chamber and immersed in chemically pure water (Water never needs replacement)
- Steam transfers heat evenly to entire cooking surface with only ±5°F (±3°C) in temperature variation
- Rapid surface temperature recovery allows turning product to same spot
- Smooth cold-rolled stainless steel griddle surface speeds and simplifies cleaning

Standard Control Features

- Heating indicator light
- 200–400°F (93–204°C) digital thermostat
- Easy front service access to controls
- Control guard
- 3 preset temperatures capable
- Manager mode to lock out temperature controls
- Over temperature indicator light

Cooking Capacity & Applications

Effective Cooking Area

Depth	24" Wide	36" Wide	48" Wide
30"	717 sq. in.	1077 sq. in.	1437 sq. in.
24"	574 sq. in.	862 sq. in.	1150 sq. in.

Griddle Applications include:

- Pancakes, Eggs, Sausage, French Toast
- Burgers, Grilled Onions, Toasted Buns
- Grilled Cheese, Sandwiches
- Fried Potatoes, Fish, Chicken Breasts, Philly Steaks, Liver and MORE

Environmental Approvals & Programs



Other Approvals



Options & Accessories

- "U" Channel for connecting 2 griddles
- Front mounted prep shelf—8" wide stainless steel
- Condiment Board
- Maritime Package (call for details)
- Correction Package (call for details)
- Chain Package (call for details)
- Heavy duty stainless steel stand with bottom shelf and 5" casters



EGF-A36 Accu-Steam™
Tabletop Griddle shown

Accu-Steam Griddle Specifications (replace **** with voltage & phase, i.e. 2083)						
Model #	EGF****A2450-T1	EGF****B2450-T1	EGF****A3650-T1	EGF****B3650-T1	EGF****A4850-T1	EGF****B4850-T1
KW Input	9.6 kW	9.6 kW	14.25 kW	14.25 kW	14.25 kW	14.25 kW
208/3 Amp Load	27A / 9.6 kW	27A / 9.6 kW	40A / 14.25 kW	40A / 14.25 kW	40A / 14.25 kW	40A / 14.25 kW
240/1 Amp Load	40A	40A	n/a	n/a	n/a	n/a
240/3 Amp Load	24A / 9.6 kW	24A / 9.6 kW	34A / 14.25 kW	34A / 14.25 kW	34A / 14.25 kW	34A / 14.25 kW
440/3 Amp Load	14A / 11 kW	14A / 11 kW	21A / 16 kW	21A / 16 kW	21A / 16 kW	21A / 16 kW
480/3 Amp Load	16A / 13kW	16A / 13kW	23A / 19kW	23A / 19kW	23A / 19kW	23A / 19kW
Unit Width (A)	24.25 [616]	24.25 [616]	36.25 [921]	36.25 [921]	48.25 [1226]	48.25 [1226]
Unit Depth (D)	34.7 [881]	28.7 [729]	34.7 [881]	28.7 [729]	34.7 [881]	28.7 [729]
Cooking Surface Width (B)	23.9 [607]	23.9 [607]	35.9 [912]	35.9 [912]	47.9 [1217]	47.9 [1217]
Cooking Surface Depth (C)	30 [762]	24 [610]	30 [762]	24 [610]	30 [762]	24 [610]
Depth to Rear Leg (E)	8.5 [216]	2.5 [64]	8.5 [216]	2.5 [64]	8.5 [216]	2.5 [64]
Center right to left (F)	20 [508]	20 [508]	32 [813]	32 [813]	44 [1117]	44 [1117]
Effective Cooking Area	717 sq. in.	574 sq. in.	1077 sq. in.	862 sq. in.	1437 sq. in.	1150 sq. in.
Grease Pan Capacity	5 qt	5 qt	6 1/2 qt	6 1/2 qt	6 1/2 qt	6 1/2 qt
NEMA Plug (208/240)	15-50P	15-50P	15-50P	15-50P	15-50P	15-50P
NEMA Plug (440/480)	L16-20P	L16-20P	L16-30P	L16-30P	L16-30P	L16-30P

Notes:

- 1.) Dimensions in brackets [] are metric.
- 2.) 5' power cord with plug provided.

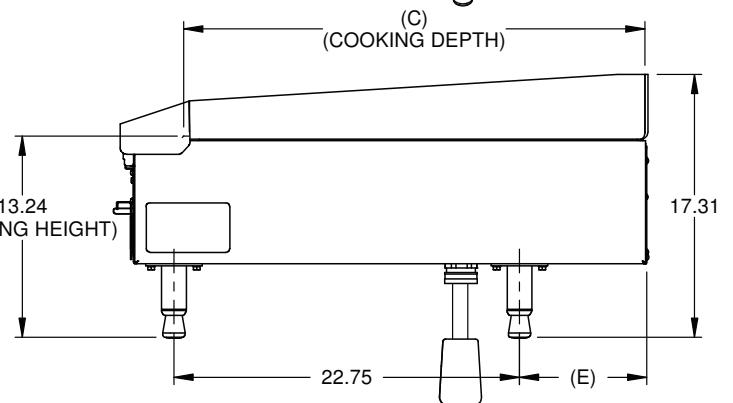
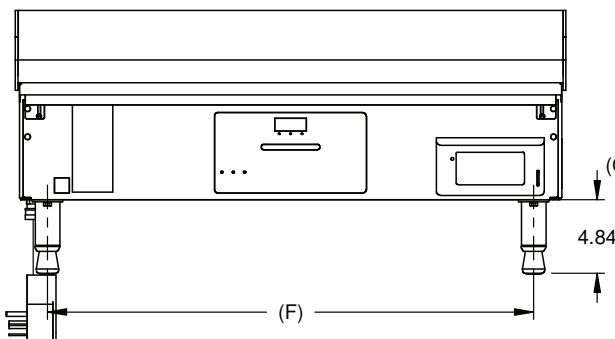
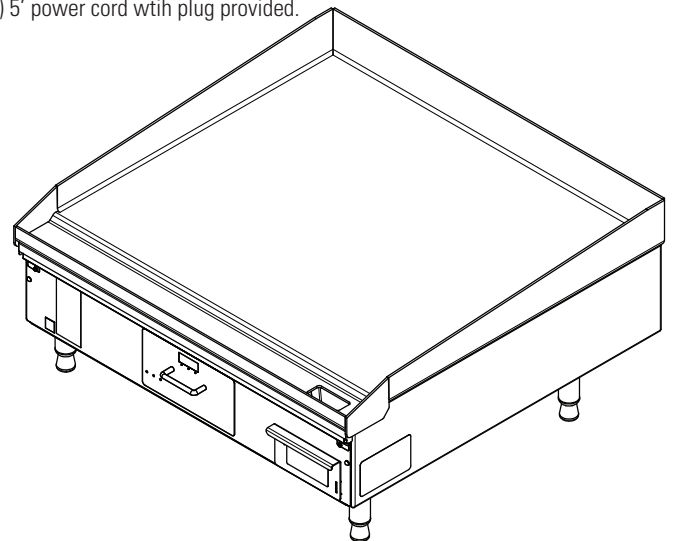
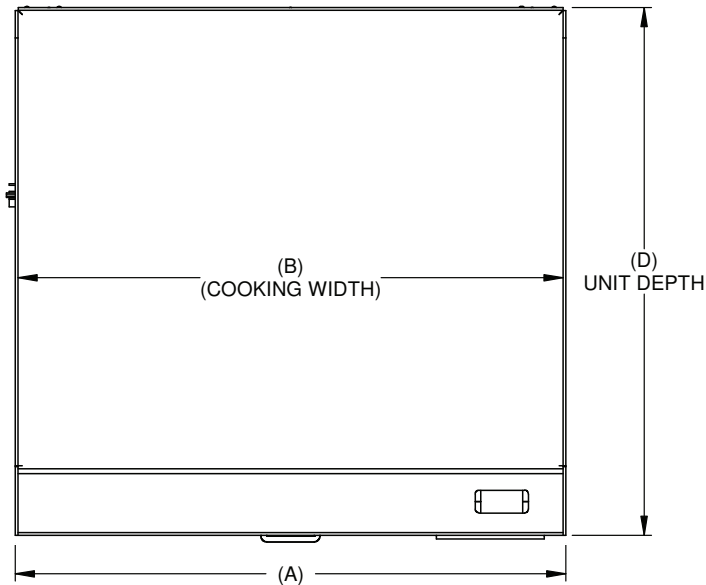

MM5206-1708