

Tech Spec 6

Reinstatement of Interlocking Concrete Pavements

Introduction

Concrete pavers can act as a zipper in the pavement. When the need arises to make underground repairs, interlocking concrete pavements can be removed and replaced using the same material. Unlike asphalt or poured-in-place concrete, segmental pavement can be opened and closed without using jack hammers on the surface and with less construc-

tion equipment. This results in no ugly patches and no reduction in pavement service life. In addition, no curing means fast repairs with reduced user delays and related costs.

The process of reusing the same paving units is called reinstatement. This Tech Spec covers how to reinstate or

“unzip and zip” interlocking concrete pavement. The following step-by-step procedure applies to any interlocking concrete pavement, including pedestrian areas, parking lots, driveways, streets, industrial, port and airport pavements.

Step 1—Locate Underground Utilities in the Area to be Excavated

The location and depth of existing utilities should be established prior to excavating. Many localities have one telephone number to call for obtaining marked utility locations. Set cones, traffic signs, or barricades around the area to be excavated according to local and state or provincial standards.

Determine and mark the area of pavers to be removed. Remove pavers a few feet (~0.8 m) wider on each side of the trench open-

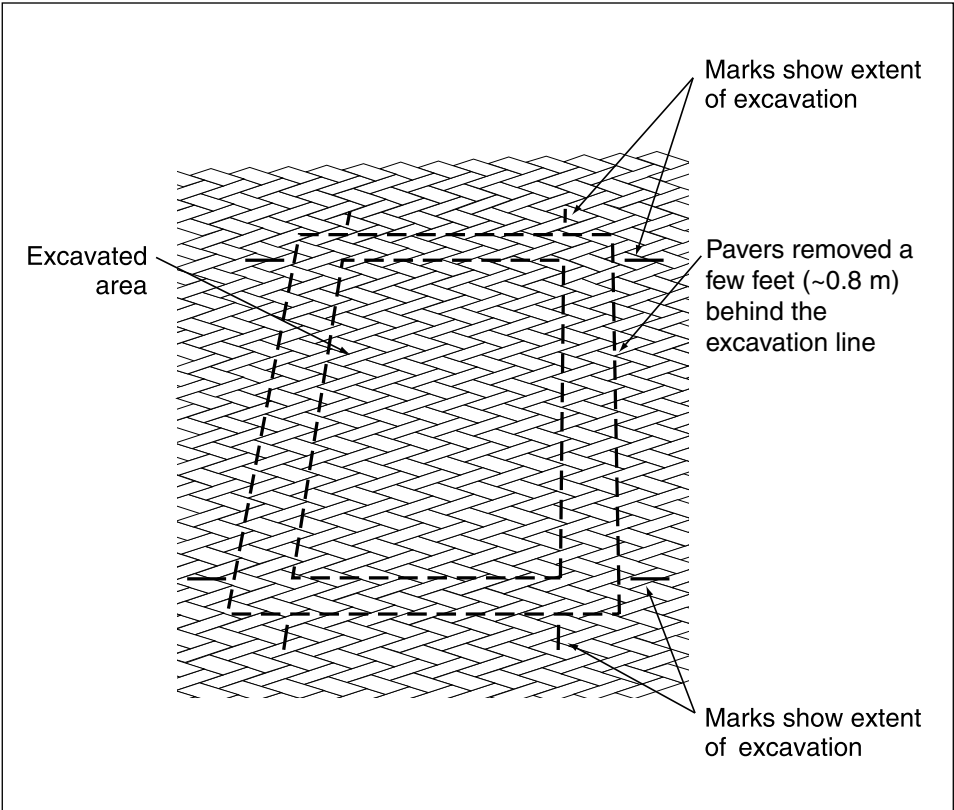

Figure 1. Pavement markings show the extent of paver removal and trench area.

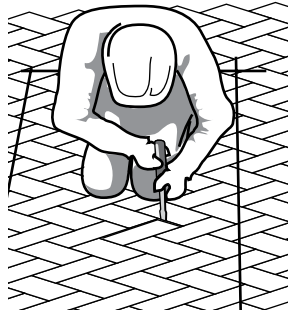

Figure 2. Removing joint sand surrounding the first paver to be removed.

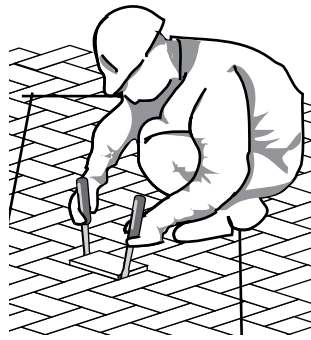

Figure 3. Prying the paver upwards with two large screwdrivers.



Figure 4. Prying with a screwdriver and pulling the paver out.

ing. This shoulder around the opening should consist of undisturbed bedding sand. It will be used as a guide for reinstating the sand and pavers later (Figure 1).

Paint or crayon should be used to mark the area of pavers for removal. The trench area can be marked on the pavers as well. Paint may be necessary to establish a more permanent

marking than crayon, especially if there is vehicular traffic, or if there will be an extended period of time between marking and excavation. The same paving units will be reused, so in some instances paint on them may not be desirable, especially if there is little traffic to wear it away over time.

Step 2—Remove the First Paver

Locate the first paver to be removed. This is typically at one end of the marked area. Scrape the sand from the joints around the first paver using a putty knife or small trowel (Figure 2). Carefully pry each side upward with one or two large screwdrivers. Begin prying on the short ends of the paver. The paver will rise a small distance with each prying (Figure 3). When the paver is high enough to grasp, wiggle it loose, pulling upward. If necessary, pry with a screwdriver using one hand while pulling upward with the other (Figure 4). Sometimes, one end of the paver can be pulled above the others so a pry bar can be inserted under it. The paver can then be pried out.

Paver extractors can also be used to remove the first paver and subsequent ones (Figure 5). They are designed to clamp the paver tightly. These work most efficiently in removing the first paver if some of the joint sand is removed before clamping and pulling. Water can be applied to lubricate the joint sand to facilitate extraction.

If the pavement has been subject to vehicular traffic for a length of time, the first paver may need to be broken in order to be removed. A small sledge hammer (3 lb. maul) applied to an appropriate chisel will break a paver into small pieces. Protective eye goggles should be worn during this procedure. Remove all broken pieces from the space until the bedding sand is completely exposed. Pneumatic hammers or



Figure 5. Using a paver extractor to remove a paver

cutting saws are generally not required to remove the first unit.

Step 3—Remove the Remaining Pavers

After the first one is removed, surrounding pavers can be loosened and pried out (Figure 6). Grab the pavers by the short end, as it offers less resistance than the long side (Figure 7). Remove pavers to the marks on the pavement for the opening.

Sand sticking to the sides and bottoms of pavers can interfere with their reinstatement and compaction into the bedding sand. Scrape off sand from each unit as it is being removed. A small trowel, wide putty knife, wire brush, or another paver works well.

The direction of removal should consider where pavers are going to be stacked. Stack the pavers neatly near the opening, out of the way of excavation equipment such as backhoes or dump trucks. If the pavers need to be removed from the site, stack them on wooden pallets and secure them tightly so there is no loss during transit.

Equipment used to move pallets with pavers should be capable of lifting at least 3,000 lbs. (1,365 kg). If the pavers need to be moved only a short distance, then stack them directly on a paver cart at the opening and set them nearby. They will then be ready for pick up by the paver cart when reinstated.

For every project, a small stockpile of spare pavers should be stored and used for repairs during the life of the pavement. Weathering, wear and stains may change the appearance of removed pavers compared to spares kept in storage for repairs. When pavers are removed for base or utility repairs, all undamaged units should be retained for future reinstatement. Pavers from the stockpile that replace damaged or broken units should be scattered among the pattern of the existing reinstated pavers. This will reduce the visual impact of color variations.



Figure 6. Prying out the remaining pavers



Figure 7. Pulling out a paver by the short end provides greater leverage and makes extraction easier.

Step 4—Remove the Bedding Sand

The removed pavers will reveal compacted bedding sand. It may be removed and reused, or removed during excavation of the base. For some projects with time constraints, the sand will probably be removed during excavation and not reused.

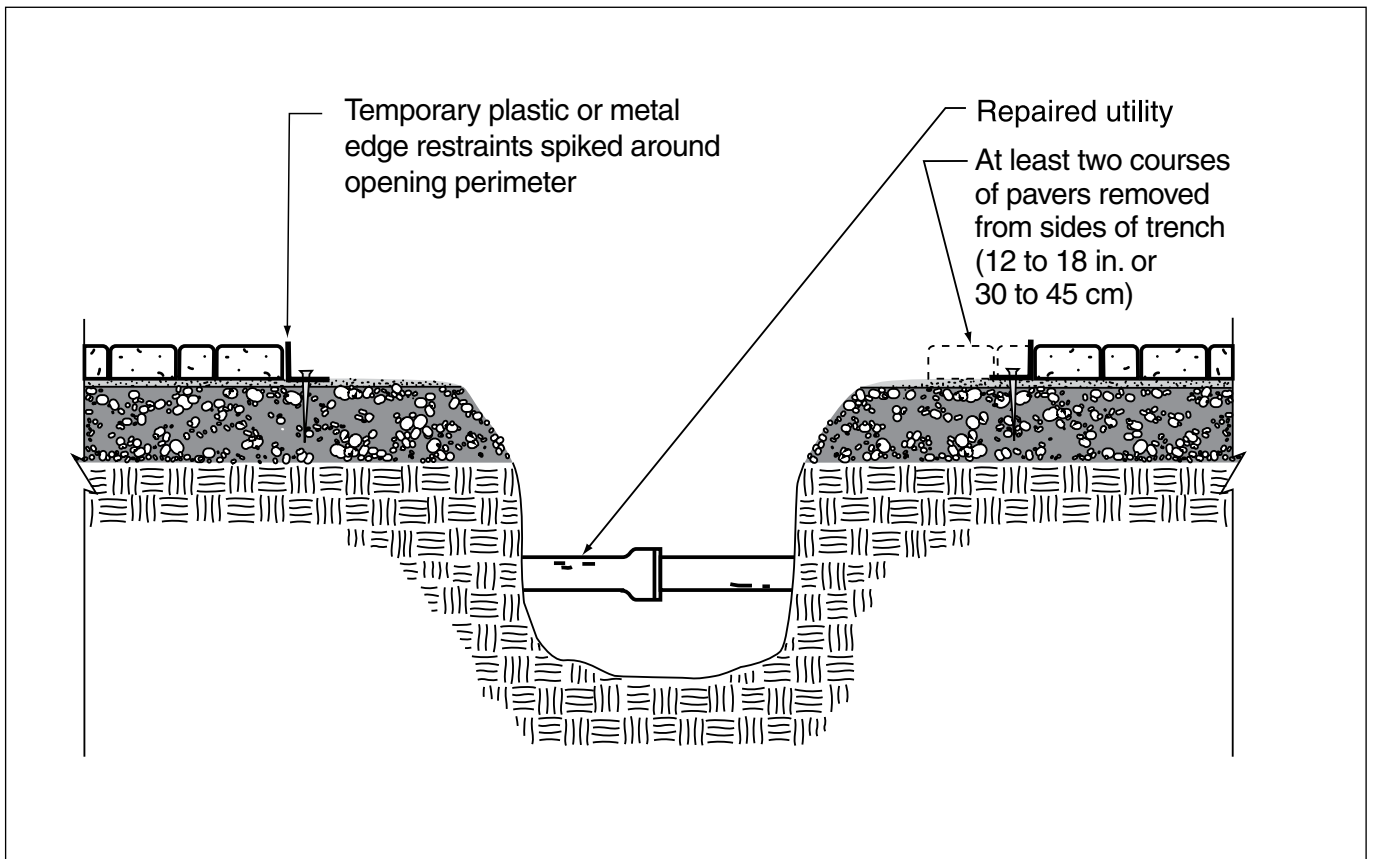

Figure 8. T-shaped cross section of the excavated opening

If the sand is reused, it may need to be loosened with rakes before removal by shoveling. The sand should be neatly stockpiled and kept free from soil, aggregate base, or foreign material. If the sand is mixed with these materials, it should not be reused, and it should be replaced with clean sand.

Whether or not it is reused, always leave an undisturbed area of sand 6 to 12 in. (15 to 30 cm) wide next to the undisturbed pavers. This area will provide a stable support for temporary edge restraints and for screeding the bedding sand after the base is reinstated.

Step 5—Excavate the Base Material and Soil

If aggregate base material is removed, it may be possible to stockpile it near the opening for reuse. Keep the aggregate base material separate from excavated subgrade soil. Any soil removed should be replaced with base material unless local regulations require reinstatement of the native soil. The final shape of the excavated opening should be T-shaped in cross section. (Figure 8). This helps prevent undermining and weakening

of the adjacent pavement. Follow local codes on the use of shoring, as it may need to be inserted to prevent collapse of the trench sides.

Figure 9 illustrates temporary bracing with plastic or metal edge restraints around the perimeter of the opening. This is recommended practice. The restraints are pinned to the base using metal spikes. Bracing helps keep the undisturbed pavers in place during excavation and fill activities, and will enable reinstatement of units into the existing laying pattern without cutting them to fit.

Step 6—Replace the Base Material

After the repairs are complete, soil at the bottom of the trench should be compacted prior to placing and compacting the base material. Repairs typically use the same base material that was removed. A crushed stone aggregate base should be placed and compacted in 2 to 4 in. (50 to 100 mm) lifts (Figures 10 and 11). If the excavated base material was stabilized with asphalt or cement, it should be replaced with similar materials.

Monitoring density of the compacted soil subgrade and base is *essential* to reinstating any pavement, including

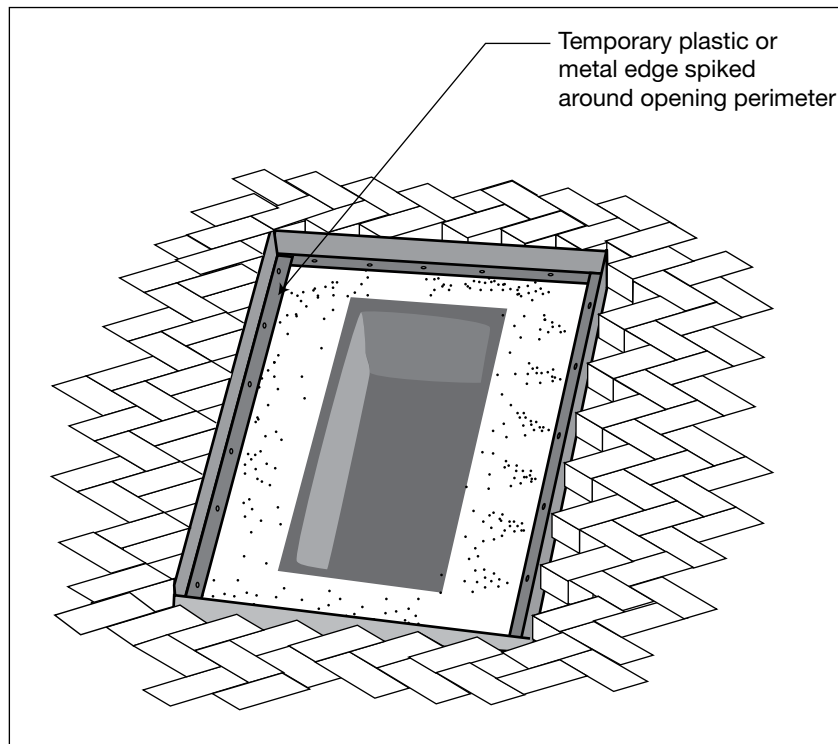

Figure 9. Temporary bracing at the pavement opening will help keep units in place during excavation, repairs and reinstatement.

interlocking concrete pavements. It will help prevent rutting and premature failure. A dynamic cone penetrometer is an effective means for monitoring the density of each lift while working in the opening. If the soil or base material is too dry during compaction, a small amount of water can be sprayed over each lift prior to compacting. This will help achieve maximum density. A nuclear density gauge is recommended for checking the density of the completed compaction of the soil and base layers. A qualified civil engineer should monitor compaction for conformance to local standards.

If there are no local standards for compaction, a minimum of 98% standard Proctor density is recommended for the soil subgrade, and a minimum of 98% modified Proctor density for the base. Compaction equipment companies can provide guidelines on equipment selection and use on the soil and the base. For further guidance on compaction see *ICPI Tech Spec 2—Construction of Interlocking Concrete Pavements*.

The final elevation of the compacted base at the opening perimeter should match the bottom of the existing undisturbed sand layer that surrounds the opening. The elevation of the middle of the base fill placed in the opening should be

slightly higher than its perimeter to compensate for minor settlement.

Controlled low-strength materials (CLSM) (sometimes called slurry mix, flowable fill, or unshrinkable fill) can be used in some applications as a replacement for unstabilized base materials (1). The fill can be made from aggregate bound with fly ash, pozzolans, or cement. Because it is poured from a truck, the fill will form around pipes and underground structures where soil or base backfill and compaction are difficult. Low-strength fill can be poured into undercuts and under pipes where it is impossible to fill and compact aggregate base. The material is also self-leveling.

Low-strength flowable fill requires a short curing time and can be used in freezing weather. It requires no compaction and with some mix designs, can be opened to traffic in 24 hours. Low-strength fill is stiffer than aggregate base and offers higher resistance to settling and rutting. This reduces deterioration of the pavement surface over time. In order to facilitate re-excavation, flowable fill should be made with a small amount of cement. Check with suppliers on the strength of in-place fill that is at least two years old, and

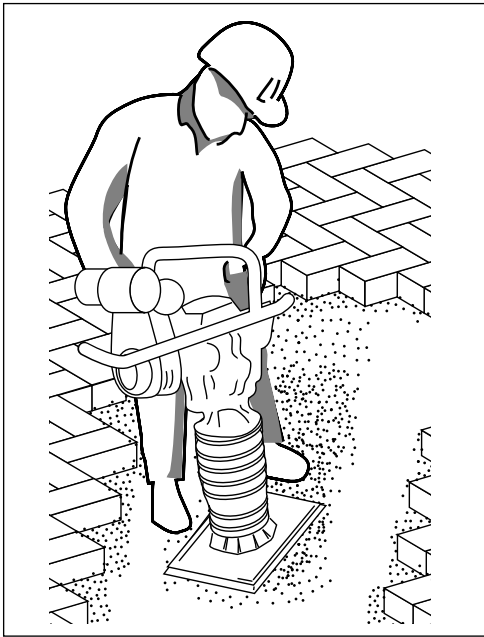

Figure 10. Compaction of the base in 2 to 4 in. (50 to 100 mm) lifts and monitoring density with a dynamic cone penetrometer or a nuclear density gauge are essential to minimizing settlement.

on ease of excavation of these sites. The strength of the fill should not exceed 300 psi (2 MPa) after two years of service. Low-strength fill has been used successfully in Toronto and London, Ontario; Colorado Springs, Colorado; Cincinnati, Ohio, Kansas City, Missouri; Peoria, Illinois; and many other municipalities. It is generally more cost-effective than using aggregate base by reducing job time and future pavement repairs. Local ready-mix suppliers can be contacted for available mixes, strengths, installation methods and prices. See *ICPI Tech Spec 7—Repair of Utility Cuts with Interlocking Concrete Pavements* for further information on low-strength fill.

Step 7—Replace the Bedding Sand Layer

During the foregoing procedures, it is likely that the pavers and bedding sand around the opening were disturbed especially if no temporary edge restraints were placed to secure the pavers. If so, then remove an additional two rows of pavers, or back to an undisturbed course. Clean sand from these pavers and set them aside with the others. Be sure there is at least 6 to 8 in. (150 to 200 mm) of undisturbed bedding sand exposed after removal of the course(s) of pavers. This area of undisturbed sand can be used to guide screeding of fresh bedding sand over the compacted and leveled base. Prior to screeding, carefully remove any temporary

edge restraints so that adjacent pavers remain undisturbed.

Spread the bedding sand across the base to about two thirds of its full thickness. Do not use the sand to compensate for low places in the surface of the base. Low areas should be filled with base material and compacted. Spread the remaining thickness of sand.

The undisturbed pavers on opposite sides of the opening can be used to guide screeding. It may be necessary to remove a few courses of pavers to straighten the edge of the pavers (Figure 12).

Metal screed pipes are placed on the base and in the bedding sand to control its thickness. The base should have a slight “crown” or rise in the center of the reinstated base. A crown helps compensate for minor settling after the pavers are replaced. Furthermore, as the pavers settle slightly from traffic, the reinstated surface will stiffen, increasing its structural capacity.

Step 8—Reinstate the Pavers

Pull and secure string lines across the opening along the pavement joints every 6 to 10 ft. (2 to 3 m). By following the string lines, joints of reinstated pavers will remain aligned with undisturbed ones. Lay the remaining pavers from the smaller end of the opening, generally working “uphill,” i.e., from a lower elevation of the pavement to the higher one. Minor adjustments to the alignment and spacing of joints can be made with pry bars or large screw drivers. Make adjustments prior to compacting the pavers (Figure 13).

Place the pavers in the original laying pattern and compact them with at least two passes of a minimum 5,000 lbf. (22 kN) plate compactor. The path of the plate compactor should overlap onto the undisturbed pavers. Spread joint sand and compact again until the joints can no longer accept sand (Figure 14). Sweep away excess sand. The elevation of the reinstated pavers after compaction should be no higher than 1/8 in. (2 mm) at the edges and 3/16 in. (5 mm) at the center. Traffic and minor settlement will compact the pavers to a level surface. After a short period of time, the repaired area will be undetectable (Figure 15).

Applications such as airports or gas stations require joint sand stabilizers. If an area is reinstated in such uses, then a stabilizer will need to be re-applied to the joints. See *ICPI Tech Spec 5—Cleaning and Sealing Interlocking Concrete Pavements* for advice on sealers and joint sand stabilizers.

A crew of three or four persons can manually reinstate between 500 and 1,500 sf (50 and 150 m²) per day. This does not include excavation and replacement of the base material. Crew productivity depends on experience, weather, traffic, site access, a steady flow of materials around the repair site,



Figure 11. Trench filled with compacted aggregate base. Temporary edge restraints should be used around the opening perimeter.



Figure 12. Screeded bedding sand. Note that a few courses of pavers are removed to create even sides for screeding. Installing temporary edge restraints prior to excavating is preferred practice.

and the number of pavers to be cut. An experienced crew will reinstate pavers with little or no cutting, aligning reinstated pavers with existing joint lines, pattern, and spacing between the units.

Although existing pavers can be used in reinstatement, there may be projects where it is more cost-effective to remove and replace the area with new pavers. An experienced paver installation contractor can provide guidance on cost-effective approaches for each reinstatement project.

Municipalities, utility companies and other users should use experienced ICPI Certified Installer to reinstate interlocking concrete pavers. Others may use in-house labor which should be trained in the procedures described above. Contact a local Interlocking Concrete Pavement Institute paver installation contractor member to assist with training. Successful reinstatement using experienced contractors will result in successful reinstatement jobs that leave no ugly



Figure 13 (Left). Adjusting joint spacing and alignment. Figure 14 (Right). Second and final compaction of the pavers. The first compaction occurs after the pavers are placed (no sand in the joints). The second compaction works the sand on pavers into the joints. This process causes the pavers to interlock.

patches nor do they weaken the pavement. See Figures 15 and 16.

References

1. *Controlled Low Strength Materials (CLSM)*, ACI 229R-94, American Concrete Institute, Farmington Hills, Michigan, 1994.

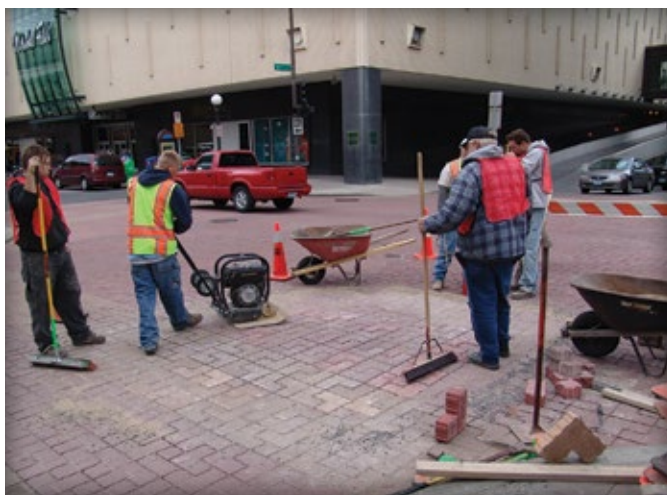

Figure 15 and 16. Reinstated pavers leave no ugly patches nor do they weaken the pavement.



Interlocking Concrete
Pavement Institute

14801 Murdock Street
Suite 230
Chantilly, VA 20151

Tel: 703.657.6900
Fax: 703.657.6901
E-mail: icpi@icpi.org
www.icpi.org

In Canada:
P.O. Box 1150
Uxbridge, ON L9P 1N4
Canada

The content of ICPI Tech Spec technical bulletins is intended for use only as a guideline. It is not intended for use or reliance upon as an industry standard, certification or as a specification. ICPI makes no promises, representations or warranties of any kind, expressed or implied, as to the content of the Tech Spec Technical Bulletins and disclaims any liability for damages resulting from the use of Tech Spec Technical Bulletins. Professional assistance should be sought with respect to the design, specifications and construction of each project.